



e-Watch®

24V CAM to KIT304 Wiring

e-Watch Corporation

7800 IH-10 West, Suite 720
San Antonio, TX 78230
USA

www.e-watch.com
tel: 210 349-2000
fax: 210 341-1020

READ THIS NOTICE

THE SPECIFICATIONS AND INFORMATION REGARDING THE PRODUCTS IN THIS MANUAL ARE SUBJECT TO CHANGE WITHOUT NOTICE. ALL STATEMENTS, INFORMATION, AND RECOMMENDATIONS IN THIS MANUAL ARE BELIEVED TO BE ACCURATE BUT ARE PRESENTED WITHOUT WARRANTY OF ANY KIND, EXPRESS OR IMPLIED. USERS MUST TAKE FULL RESPONSIBILITY FOR THEIR APPLICATION OF ANY PRODUCTS.

THE SOFTWARE LICENSE AND LIMITED WARRANTY FOR THE ACCOMPANYING PRODUCT ARE SET FORTH IN THE INFORMATION PACKET THAT SHIPPED WITH THE PRODUCT AND ARE INCORPORATED HEREIN BY THIS REFERENCE. IF YOU ARE UNABLE TO LOCATE THE SOFTWARE LICENSE OR LIMITED WARRANTY, CONTACT YOUR E-WATCH REPRESENTATIVE FOR A COPY. NOTWITHSTANDING ANY OTHER WARRANTY HEREIN, ALL DOCUMENT FILES AND SOFTWARE OF THESE SUPPLIERS ARE PROVIDED 'AS IS' WITH ALL FAULTS. E-WATCH AND ITS SUPPLIERS DISCLAIM ALL WARRANTIES, EXPRESSED OR IMPLIED, INCLUDING, WITHOUT LIMITATION, THOSE OF MERCHANTABILITY, FITNESS FOR A PARTICULAR PURPOSE AND NONINFRINGEMENT OR ARISING FROM A COURSE OF DEALING, USAGE, OR TRADE PRACTICE.

IN NO EVENT SHALL E-WATCH OR ITS SUPPLIERS BE LIABLE FOR ANY INDIRECT, SPECIAL, CONSEQUENTIAL, OR INCIDENTAL DAMAGES, INCLUDING, WITHOUT LIMITATION, LOST PROFITS OR LOSS OR DAMAGE TO DATA ARISING OUT OF THE USE OR INABILITY TO USE THIS MANUAL, EVEN IF E-WATCH OR ITS SUPPLIERS HAVE BEEN ADVISED OF THE POSSIBILITY OF SUCH DAMAGES.

UNITED STATES FEDERAL COMMUNICATIONS COMMISSION NOTICE

The following information is for FCC compliance of Class A devices: This equipment has been tested and found to comply with the limits for Class A digital device, pursuant to part 15 of the FCC rules. These limits are designed to provide reasonable protection against harmful interference when the equipment is operated in a commercial environment. This equipment generates, uses, and can radiate radio-frequency energy and, if not installed and used in accordance with the instruction manual, may cause harmful interference to radio communications. Operation of this equipment in a residential area is likely to cause harmful interference, in which case users will be required to correct the interference at their own expense.

You can determine whether your equipment is causing interference by turning it off. If the interference stops, it was probably caused by the e-Watch® equipment or one of its peripheral devices. If the equipment causes interference to radio or television reception, try to correct the interference by using one or more of the following measures:

- Turn the television or radio antenna until the interference stops.
- Move the equipment to one side or the other of the television or radio.
- Move the equipment farther away from the television or radio.
- Plug the equipment into an outlet that is on a different circuit from the television or radio. (That is, make certain the equipment and the television or radio are on circuits controlled by different circuit breakers or fuses.)

Modifications to this product not authorized by e-Watch could void the FCC approval and negate your authority to operate the product.

COPYRIGHT AND TRADEMARK NOTICE

Copyright© 2003-2006 e-Watch Corporation. All rights reserved. e-Watch is a registered trademark of e-Watch Corporation. ViewWatch, DecisionWatch, EventWatch, SiteWatch, MotionWatch, GateWatch, AirWatch, PocketWatch, PeopleWatch, BankWatch, ClassWatch, ObjectWatch, WatchLink, Activity Gated Storage, and Gigapixel are trademarks of e-Watch Corporation. Any other trademarks mentioned in this document are the property of their respective owners.

The use of the word partner does not imply a partnership relationship between e-Watch and any other company.

e-Watch systems do not prevent crimes from being committed, but are intended to be used to monitor and investigate.

e-Watch components are electronic devices and complex commercial software products. As such, they may fail on occasion. Multiple devices with overlapping zones should be used for redundancy.

e-Watch event notification capabilities must be user programmed and activated prior to use. System reliability is dependent on the underlying network infrastructure and associated communications services that may fail on occasion. The user of the e-Watch system is advised to evaluate risk associated with network failures and operator errors. Routine auditing and preventive maintenance of the system is essential to assure optimum performance.

Event analysis and recreation is subject to system configuration, lighting conditions, environmental conditions, lens and housing cleanliness, distance to subject, operator-invoked control settings, and many other factors.

Read and follow all documentation to assure proper performance.

C O N T E N T S

Preface

- Purpose
- Audience
- Organization
- Conventions
- Obtaining Documents
- Documentation Feedback
- Obtaining Assistance

PART 1	Installation Guide
CHAPTER 1	OVERVIEW 1 KIT-304 1 Possible Wiring 2
CHAPTER 2	POWER REQUIREMENTS 3 Power Supply 3 Distance 4
CHAPTER 3	WIRING 5 Wiring The Power Supply 5 Wiring The Camera Housing 6 Wiring The Pan/Tilt Unit 8
PART 2	
APPENDIX A	COMPLETED SYSTEM 10
APPENDIX B	CUSTOMER SUPPLIED EQUIPMENT 11

PREFACE

The preface describes the purpose, audience, organization, and conventions of this guide and provides information on how to obtain related documents.

The preface covers these topics:

- **Purpose**
- **Audience**
- **Organization**
- **Related Documentation**
- **Conventions**
- **Obtaining Documentation**
- **Documentation Feedback**
- **Obtaining Assistance**

Purpose

This document provides instructions for the wiring of a KIT-304 to an outdoor e-Watch® camera. It provides illustrations of the connections and construction required. This document acts as an illustrated guide for hardware wiring.

Audience

This guide provides information for hardware wiring and is intended for qualified technicians involved in hardware wiring, maintenance, and repair. This guide requires knowledge of electronic hardware installation and tools. Ability to lift five to ten pounds is required for installation of the unit. This installation may pose a risk of injury if not installed by qualified technicians.

Organization

This guide is organized as shown in the following table

Part	Description
Part 1	‘Wiring Guide’ Contains information on wiring a KIT-304 to an external camera. Diagrams and procedures are included.
Part 2	‘Appendix’ Contains an illustration of a completed KIT-304 to external cam.

Related Documentation

Refer to the following documents for further information about related e-Watch applications and products:

- **URG-9128-001—Installation Guide for KIT-304**

Conventions

This document uses the following conventions:

CONVENTION	DESCRIPTION
Boldface font	Commands and keywords are in boldface .
<i>Italic font</i>	Arguments for which you supply values are in <i>italics</i> .
[]	Elements in square brackets are optional.
{x y z}	Alternate keywords are grouped in brackets and separated by vertical bars.
[x y z]	Optional keywords are grouped in brackets and separated by vertical bars.
String	A non-quoted set of characters. Do not use quotation marks around the string or the string will include the quotation marks.
Screen font	Terminal sessions and information the system displays are in screen font.
Boldface font screen font	Information you must enter is in boldface screen font .

<i>Italic</i> screen font	Arguments for which you supply values are in <i>italic</i> screen font.
^	The symbol ^ represents the key labeled Control - for example, the key combination of ^D in a screen display means hold down the Control key while you press the D key.
-->	This pointer highlights an important line of text in an example.
<>	Non-printing characters, such as passwords, are in angle brackets.

Obtaining Documentation

The following sections provide sources for obtaining documentation from e-Watch Corporation.

World Wide Web

e-Watch documents can be found by going to the e-Watch web site www.e-watch.com

By Mail

e-Watch Corporation
 7800 IH 10 West, Suite 720
 San Antonio, Texas 78230
 210.349.2000
support@e-watch.com

Documentation Feedback

You can submit technical comments about e-Watch documentation in the following ways:

E-mail your comments to support@e-watch.com

To submit comments by mail, write to the following address:

e-Watch Corporation
 7800 IH 10 West, Suite 720
 San Antonio, Texas 78230

We appreciate your comments.

Obtaining Assistance

The following sections provide sources for obtaining assistance from e-Watch Corporation.

Customer Support

For technical assistance please send requests to support@e-watch.com or your local e-Watch reseller. You may also call 210-349-2000 and ask for Customer Support.

Sales

For assistance with sales or marketing please call 210-349-2000 and ask for Sales or send requests to sales@e-watch.com

Overview

KIT-304

This document will cover the wiring of an external e-Watch® camera to a KIT-304.



Figure 1-1 Completed Unit

The KIT-304 Pan/Tilt Kit provides integrated support for the e-Watch outdoor camera and software. It is a self-contained unit for outdoor use. The unit has 355° horizontal motion and $\pm 90^\circ$ vertical motion.

Warning: This install will require opening the e-Watch camera and working with electrical devices that may pose a risk of electric shock. This install should be done by trained personnel only.

Possible Wiring

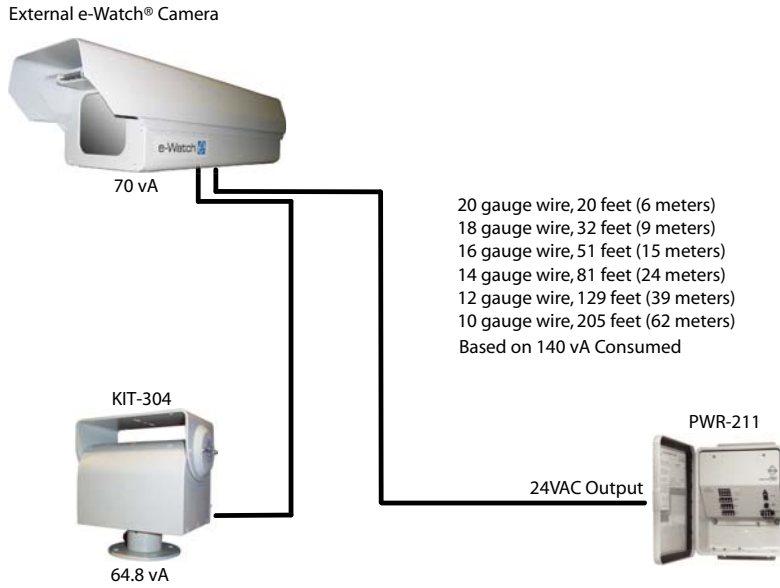

Figure 1-2 Single Wiring

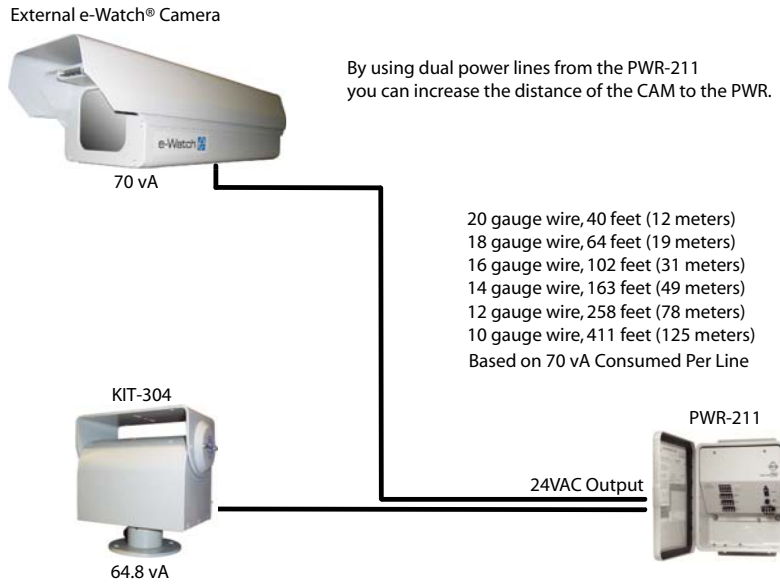

Figure 1-3 Dual Wiring

Power Requirements

Power Supply

The power supply must be able to supply 24VAC to both the pan/tilt unit and the external camera. The external camera can use an estimated 70vA, while the pan/tilt unit can use an estimated 64.8vA, we will round it all up to 140vA. For our example we use a PWR-211, this unit can supply the 140vA 24VAC required.



Figure 2-1 PWR-211

Distance

The wire gauge limits the distance between the power supply to the KIT-304. Please see Table 2-1 for wiring gauge details.

Table 2-1 Wiring Gauge Based On 140vA Consumed

Gauge	Distance
20	20 Feet (6 meters)
18	32 Feet (9 meters)
16	51 Feet (15 meters)
14	81 Feet (24 meters)
12	129 Feet (39 meters)
10	205 Feet (62 meters)

It is possible to increase the distance of the power cable by using double lines. This will reduce the required power for each cable.

Table 2-2 Wiring Gauge Based On 70vA Consumed

Gauge	Distance
20	40 Feet (12 meters)
18	64 Feet (19 meters)
16	102 Feet (31 meters)
14	163 Feet (49 meters)
12	258 Feet (78 meters)
10	411 Feet (125 meters)

Wiring

Wiring The Power Supply

The PWR-211 should be installed by certified personnel in a secure location. Once the PWR-211 is installed in its permanent location, you can connect the camera power lines. Connect the power lines to the PWR-211 please verify the wire gauge with “*Table 2-1 Wiring Gauge Based On 140vA Consumed*” on page 4 for single pair, or “*Table 2-2 Wiring Gauge Based On 70vA Consumed*” on page 4 for double pair.

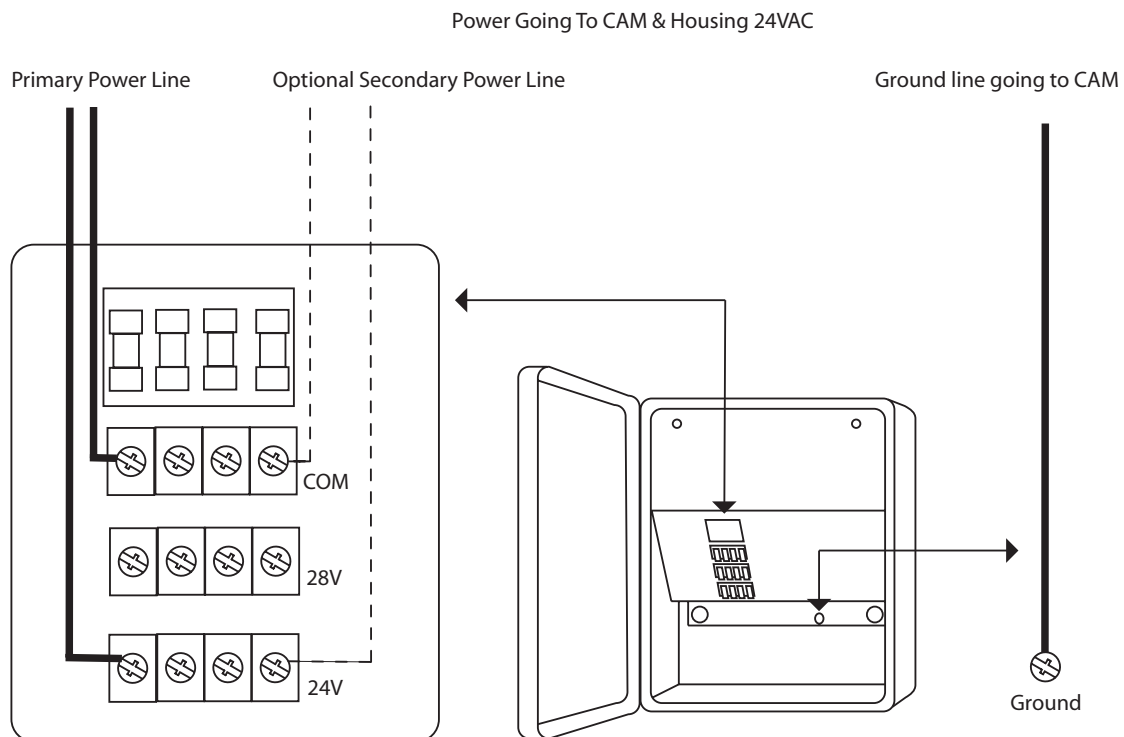

Figure 3-1 PWR-211 Wiring

Wiring The Camera Housing

To add power to the external camera please follow these steps.

1. Open the external camera housing.
2. Remove one of the plastic cable plugs from the housing

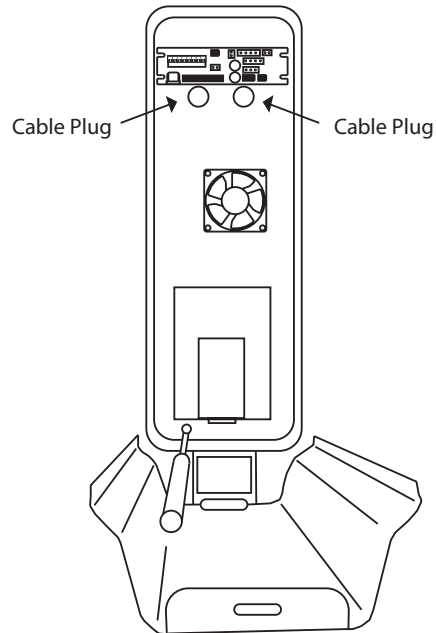

Figure 3-2 Cable Plugs

3. Assemble and install the Cable Gland

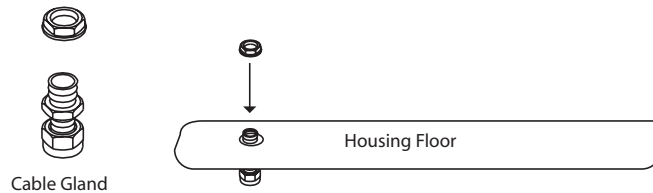

Figure 3-3 Cable Gland

4. Run the power cable from the bottom of the camera housing thru the cable gland into the housing.

5. Connect the 3 power lines to the camera

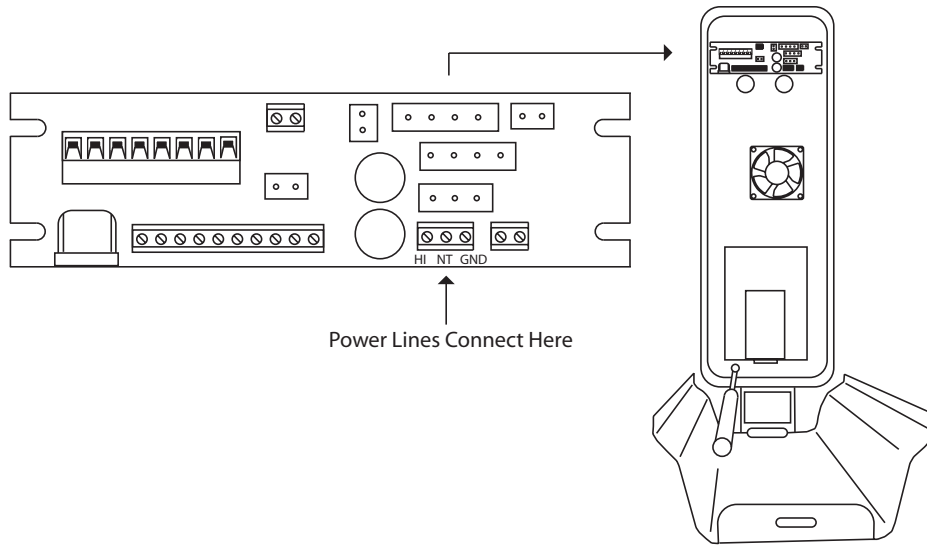
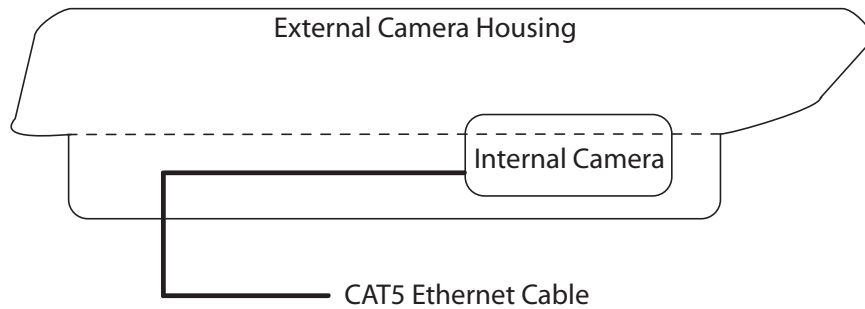

Figure 3-4 Power Line Connection

Ethernet Wiring

Unless the external camera is wireless, it will require a CAT5 cable connection. Run the CAT5 cable thru a cable gland on the external housing and connect it to the internal camera.



Wiring The Pan/Tilt Unit

Insert the pan/tilt option card into the camera inside the external camera housing. Please see document URG-9128-001 for details. If you are using one pair of wires from the power supply, connect the pan/tilt power lines to the main camera power connectors. Connect the wires to the HI and NT connections. If you are using double pairs of wires, connect the pan/tilt power cables to the second set of wires.

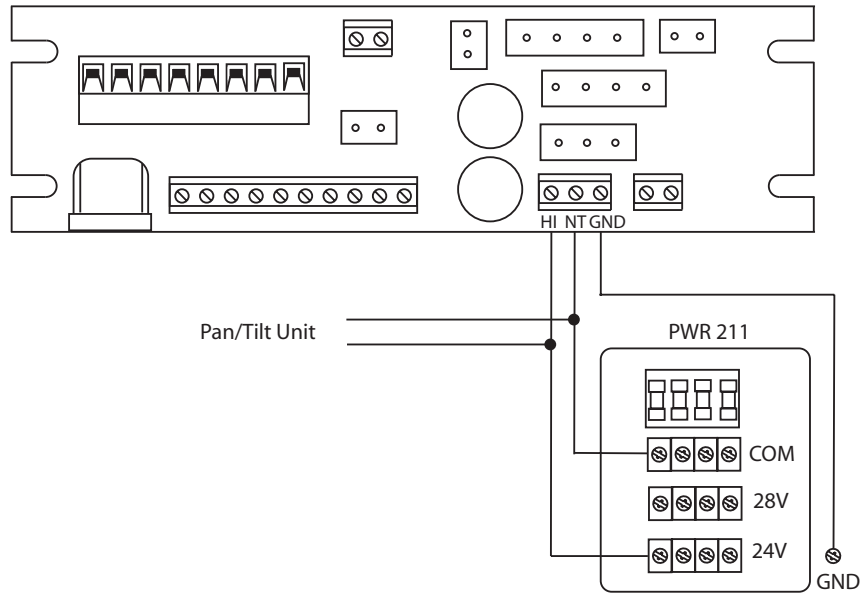

Figure 3-1 Single pair of wires from power supply

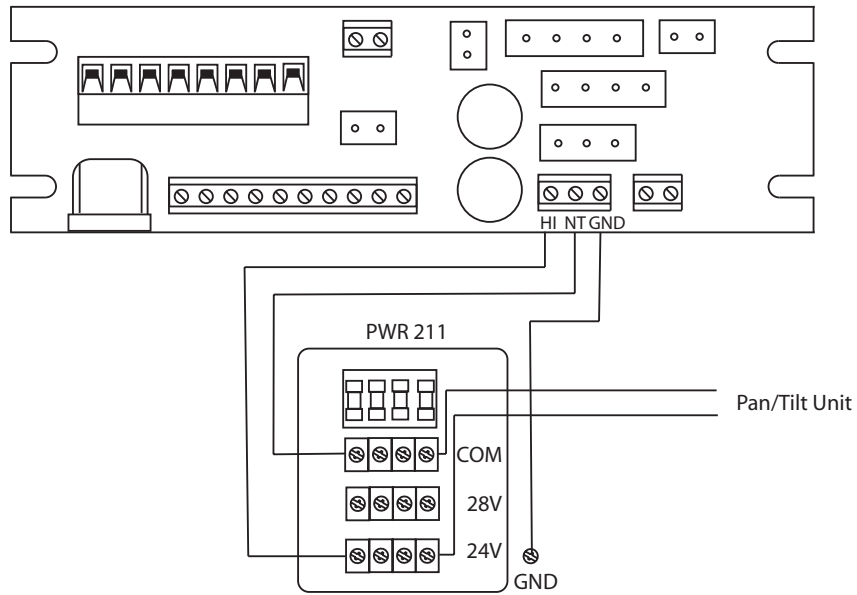

Figure 3-2 Double pair of wires from power supply

Completed System

The outdoor camera connected to the KIT-304 should look similar to Figure A-1 when completed.



Figure A-1. KIT-304 Outdoor Pan/Tilt Kit with External e-Watch® camera

Customer Supplied Equipment

The following equipment and tools are required. The customer is assumed to have already purchased an external e-Watch® camera and KIT-304. Power supply and mounting brackets are also required from the customer to complete installation.

1. Equipment

- a. **External e-Watch® camera**
- b. **KIT-304**
- c. **24 VAC (1.5 amp) Power Supply - Example PWR-211**
- d. **Mounting Bracket for Pan/Tilt Unit**

2. Tools

- a. **#1 Philips Screwdriver or T-9 Torx Driver**
- b. **10 mm Wrench**