



e-Watch®

Installation Guide for DOM-1XX

e-Watch Corporation

7800 IH-10 West, Suite 720
San Antonio, TX 78230
USA

www.e-watch.com
tel: 210 349-2000
fax: 210 341-1020

READ THIS NOTICE

THE SPECIFICATIONS AND INFORMATION REGARDING THE PRODUCTS IN THIS MANUAL ARE SUBJECT TO CHANGE WITHOUT NOTICE. ALL STATEMENTS, INFORMATION, AND RECOMMENDATIONS IN THIS MANUAL ARE BELIEVED TO BE ACCURATE BUT ARE PRESENTED WITHOUT WARRANTY OF ANY KIND, EXPRESS OR IMPLIED. USERS MUST TAKE FULL RESPONSIBILITY FOR THEIR APPLICATION OF ANY PRODUCTS.

THE SOFTWARE LICENSE AND LIMITED WARRANTY FOR THE ACCOMPANYING PRODUCT ARE SET FORTH IN THE INFORMATION PACKET THAT SHIPPED WITH THE PRODUCT AND ARE INCORPORATED HEREIN BY THIS REFERENCE. IF YOU ARE UNABLE TO LOCATE THE SOFTWARE LICENSE OR LIMITED WARRANTY, CONTACT YOUR E-WATCH REPRESENTATIVE FOR A COPY. NOTWITHSTANDING ANY OTHER WARRANTY HEREIN, ALL DOCUMENT FILES AND SOFTWARE OF THESE SUPPLIERS ARE PROVIDED 'AS IS' WITH ALL FAULTS. E-WATCH AND ITS SUPPLIERS DISCLAIM ALL WARRANTIES, EXPRESSED OR IMPLIED, INCLUDING, WITHOUT LIMITATION, THOSE OF MERCHANTABILITY, FITNESS FOR A PARTICULAR PURPOSE AND NONINFRINGEMENT OR ARISING FROM A COURSE OF DEALING, USAGE, OR TRADE PRACTICE.

IN NO EVENT SHALL E-WATCH OR ITS SUPPLIERS BE LIABLE FOR ANY INDIRECT, SPECIAL, CONSEQUENTIAL, OR INCIDENTAL DAMAGES, INCLUDING, WITHOUT LIMITATION, LOST PROFITS OR LOSS OR DAMAGE TO DATA ARISING OUT OF THE USE OR INABILITY TO USE THIS MANUAL, EVEN IF E-WATCH OR ITS SUPPLIERS HAVE BEEN ADVISED OF THE POSSIBILITY OF SUCH DAMAGES.

UNITED STATES FEDERAL COMMUNICATIONS COMMISSION NOTICE

The following information is for FCC compliance of Class A devices: This equipment has been tested and found to comply with the limits for Class A digital device, pursuant to part 15 of the FCC rules. These limits are designed to provide reasonable protection against harmful interference when the equipment is operated in a commercial environment. This equipment generates, uses, and can radiate radio-frequency energy and, if not installed and used in accordance with the instruction manual, may cause harmful interference to radio communications. Operation of this equipment in a residential area is likely to cause harmful interference, in which case users will be required to correct the interference at their own expense.

You can determine whether your equipment is causing interference by turning it off. If the interference stops, it was probably caused by the e-Watch® equipment or one of its peripheral devices. If the equipment causes interference to radio or television reception, try to correct the interference by using one or more of the following measures:

- Turn the television or radio antenna until the interference stops.
- Move the equipment to one side or the other of the television or radio.
- Move the equipment farther away from the television or radio.
- Plug the equipment into an outlet that is on a different circuit from the television or radio. (That is, make certain the equipment and the television or radio are on circuits controlled by different circuit breakers or fuses.)

Modifications to this product not authorized by e-Watch could void the FCC approval and negate your authority to operate the product.

COPYRIGHT AND TRADEMARK NOTICE

Copyright© 2003-2006 e-Watch Corporation. All rights reserved. e-Watch is a registered trademark of e-Watch Corporation. ViewWatch, DecisionWatch, EventWatch, SiteWatch, MotionWatch, GateWatch, AirWatch, PocketWatch, PeopleWatch, BankWatch, ClassWatch, ObjectWatch, WatchLink, Activity Gated Storage, and Gigapixel are trademarks of e-Watch Corporation. Any other trademarks mentioned in this document are the property of their respective owners.

The use of the word partner does not imply a partnership relationship between e-Watch and any other company.

e-Watch systems do not prevent crimes from being committed, but are intended to be used to monitor and investigate.

e-Watch components are electronic devices and complex commercial software products. As such, they may fail on occasion. Multiple devices with overlapping zones should be used for redundancy.

e-Watch event notification capabilities must be user programmed and activated prior to use. System reliability is dependent on the underlying network infrastructure and associated communications services that may fail on occasion. The user of the e-Watch system is advised to evaluate risk associated with network failures and operator errors. Routine auditing and preventive maintenance of the system is essential to assure optimum performance.

Event analysis and recreation is subject to system configuration, lighting conditions, environmental conditions, lens and housing cleanliness, distance to subject, operator-invoked control settings, and many other factors.

Read and follow all documentation to assure proper performance.

C O N T E N T S**Preface**

Purpose
 Audience
 Organization
 Conventions
 Obtaining Documents
 World Wide Web
 Obtaining Technical Assistance
 E-Mail

PART 1	Installation Guide	
CHAPTER 1	INTRODUCTION	6
	Key Features and Benefits	6
	Components Supplied with ENC-3XX	6
	Components Supplied by Customer	7
	For More Information	7
CHAPTER 2	POWER	8
	ENC Power	8
	Dome Power	10
CHAPTER 3	INSTALLATION OF THE ENC-3XX ENCODER	11
	Installing	11
	Testing	15
PART 2	Appendices	
APPENDIX A	Customer Supplied Equipment	17

PREFACE

The preface describes the purpose, audience, organization, and conventions of this guide and provides information on how to obtain related documents.

The preface covers these topics:

- Purpose
- Audience
- Organization
- Related Documentation
- Conventions
- Obtaining Documentation
- Obtaining Assistance

Purpose

This document provides instructions for the installation of the ENC-3XX to a DOM-1XX (Pelco Spectra III). The ENC-3XX Encoder is designed to work with a Pelco Spectra III. These instructions are **NOT** compatible with any other dome or pendant model. This document includes procedures for installing the Encoder and wiring the system. This document provides parts lists and diagrams for the cable connections and wiring, as well as illustrations of the connections and construction required.

Audience

This installation guide provides information for hardware installation and is intended for qualified technicians involved in hardware maintenance and repair. This guide requires knowledge of basic electronic hardware installation and tools. The ability to lift five to ten pounds is required for installation of the device.

Organization

This guide is organized as shown in the following table

Table 0-1. User Guide Organization

Part	Description
Part 1	‘Installation Guide’ Contains information on installing an ENC-3XX to a Pelco Spectra III. Diagrams and procedures are included.
Part 2	‘Appendices’ Contains listings for parts required by the customer for installation of the ENC-3XX to a Pelco Spectra III.

Related Documentation

Refer to the following documents for further information about the ENC-3XX or Pelco Spectra III.

- Pelco Spectra III installation manual C2442M (2/02)
- URG-9109-001—SiteWatch™ Situational Awareness Software Administration Guide
- URG-9126-001—e-Watch® legacy power conversion manual

Conventions

This document uses the following conventions:

Table 0-2. Conventions

Convention	Description
Boldface font	Commands and keywords are in boldface .
<i>Italic</i> font	Arguments for which you supply values are in <i>italics</i> .
[]	Elements in square brackets are optional.
{x y z}	Alternate keywords are grouped in brackets and separated by vertical bars.
[x y z]	Optional keywords are grouped in brackets and separated by vertical bars.

String	A non-quoted set of characters. Do not use quotation marks around the string or the string will include the quotation marks.
Screen font	Terminal sessions and information the system displays are in <code>screen font</code> .
Boldface screen font	Information you must enter is in boldface screen font.
<i>Italic</i> screen font	Arguments for which you supply values are in <i>italic</i> screen font.
^	The symbol ^ represents the key labeled Control - for example, the key combination of ^D in a screen display means hold down the Control key while you press the D key.
-->	This pointer highlights an important line of text in an example.
<	Non-printing characters, such as passwords, are in angle brackets.

Obtaining Documentation

The following sections provide sources for obtaining documentation from e-Watch Corp.

World Wide Web

e-Watch documents can be found by going to the e-Watch web site www.e-watch.com.

By Mail

e-Watch Corp.
 7800 IH 10 West, Suite 720
 San Antonio, Texas 78230
 210 349-2000
support@e-watch.com

Documentation Feedback

You can submit technical comments about e-Watch documentation in the following ways:

E-mail your comments to support@e-watch.com

To submit comments by mail, write to the following address:

e-Watch Corp.
7800 IH 10 West, Suite 720
San Antonio, Texas 78230

We appreciate your comments.

Obtaining Assistance

The following sections provide sources for obtaining assistance from e-Watch, Inc.

Customer Support

For technical assistance, please send requests to support@e-watch.com or your local e-Watch reseller. If you have a software maintenance agreement, call 210-349-2000 and ask for Customer Support.

Sales

For assistance with sales or marketing, please call 210-349-2000 and ask for Sales or send requests to sales@e-watch.com.

Introduction

The e-Watch® ENC-3XX serves as a connection between the Pelco Spectra III and the e-Watch® Situational Awareness System. The connection allows control of a Pelco Spectra III pendant/dome unit. This guide includes instructions for installing the Encoder with the Pelco Spectra III system.

Key Features and Benefits

The e-Watch Encoder is designed to encode legacy CCTV cameras and NTSC equipment and transmit the digital video signal over the network. The ENC-3XX allows Pelco Spectra III cameras to be fully integrated into the e-Watch IP video surveillance system. Pelco controls and components are made available through the ViewWatch™ browser-based viewer.

The e-Watch Situational Awareness System is an enterprise-wide surveillance system optimized for transmitting MPEG video streams, high resolution JPEG images, detected event data and other sensor and detector data using digital data transmission over both wired and wireless networks (LANs, WLANs). It is based on standard networking and Internet technology. Both real-time and archived data may be viewed from a monitor station or any authorized PC on the LAN, WAN or the Internet. The archive application tracks and maintains all situational awareness information and provides high-speed random access for fast location of specific data relating to events

Components Supplied with ENC-3XX

- e-Watch ENC-3XX. (*Figure 1-1*)



Figure 1-1 ENC-3XX

- The component card used in the e-Watch ENC-3XX Encoder allows for the control and support of Pelco Spectra III system. This card is pre-installed in the Encoder.

Components Supplied by Customer

- Pelco Spectra III pendant or dome camera.
- Cabling to connect the Encoder to the IP network.
- Power to the Encoder “ENC Power” on page 8
- Cabling to connect the Pelco unit to the Encoder:
 - Coaxial cable
 - CAT5 cable for controls
- Screwdriver, both Phillips and common.

For More Information

e-Watch Sales at sales@e-watch.com

e-Watch Customer Support at support@e-watch.com

Power

ENC Power

Depending on what model of ENC you have there will be specific power requirements. Some models get their power from the Ethernet, others get their power from 24VAC sources. Please see the 3XX Models table for help determining what the power requirements are for your model.

Table 2-1 3XX Models

ENC-300	.af power / legacy PoE (Power Over Ethernet)
ENC-310	24 VAC / 9-42 VDC
ENC-320	24 VAC / 12 VDC
ENC-330	24 VAC / 12 VDC
ENC-340	24 VAC / 9-42 VDC

ENC PoE

The ENC-300 unit is a PoE (Power over Ethernet) device. It receives its power from the same Ethernet line that feeds it data. To do this you must connect it to an IEEE 802.3af compliant switch or midspan. The ENC-300 is also capable of using PowerDsine® legacy power devices such as the 4000 series midspan. To use these devices the ENC-300 would have to be modified (Please See document URG-9126-001).

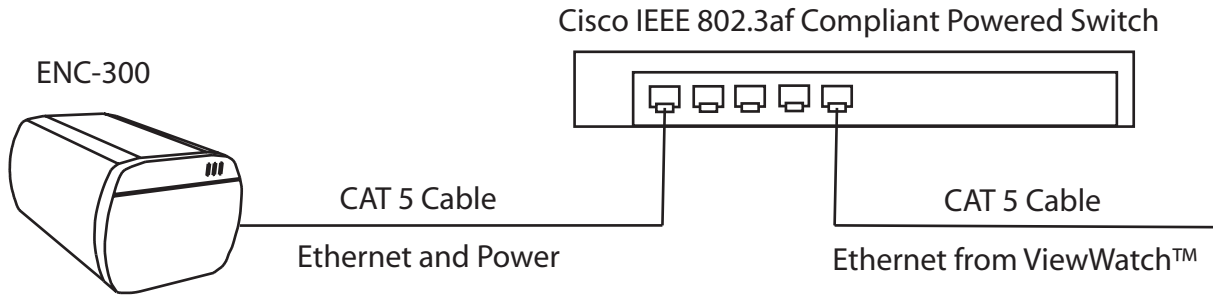

Figure 2-1 IEEE 802.3af PoE

Note: The maximum distance for PoE is 100 meters.

ENC 24VAC

The non-PoE ENC devices get their power (12Vdc / 24VAC) from either a ten prong or five prong connector. These connectors are physically different and not interchangeable. Please consult the installation guide that came included with your specific e-Watch Encoder, for details. Please see Table 2-2.

Table 2-2 Camera Power Via 12 Volt DC

Input Voltage	12Vdc / 24VAC
Maximum Power	15 Watts
Connector	Pluggable terminal strip / 16 awg max.

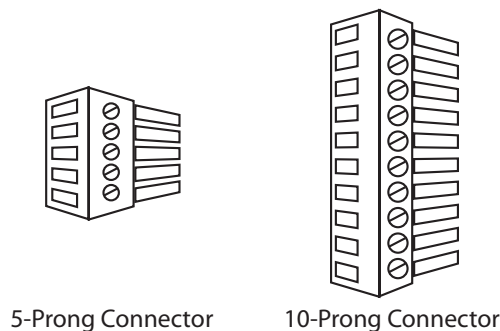

Figure 2-2 ENC Connector

Dome Power

24VAC Wiring Distances

The following are the recommended maximum distances for 24VAC applications and are calculated with a 10-percent voltage drop (10 percent is generally the maximum allowable voltage drop for AC-powered devices.)

Wire Gauge

Total vA	20	18	16	14
30	94'	150'	238'	380'
75	37'	60'	95'	152'

Note: Input power for the dome is 24VAC only. Power consumption is 30vA per dome for indoor models and 75 vA for outdoor models.

Use a 24VAC transformer with the following minimum vA:

- 40vA per dome for indoor models without heater.
- 100vA per dome for outdoor models with heater.

Installation of the ENC-3XX Encoder

Installing

Spectra III Setup

Please refer to the Pelco Spectra III installation manual C2442M (2/02) for specific instructions relating to the following steps.

1. Set SW 1-1 to the **ON** position. All other switches off. (*Figure 3-1*).

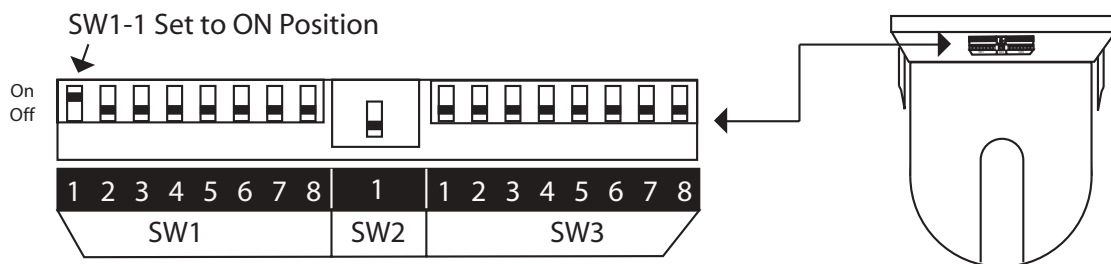

Figure 3-1 Pelco Spectra III SW Switch Settings

Wiring the Connections

These instructions cover the wiring of the e-Watch Encoder to the Pelco Spectra, using coax for video transfer from the Pelco Spectra to the e-Watch Encoder (*Figure 3-2*).

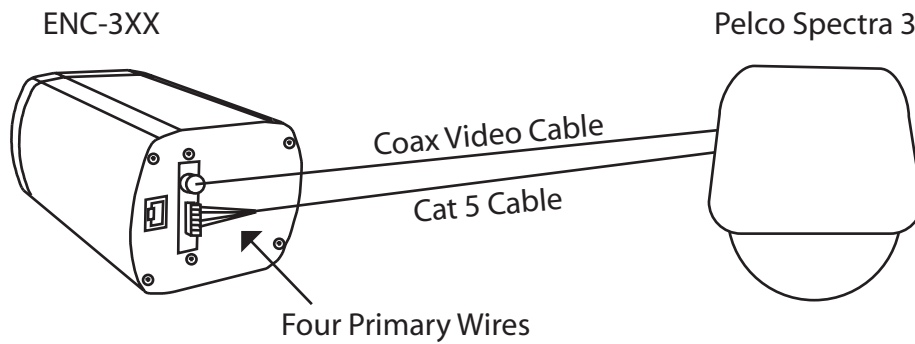

Figure 3-2 Wire Connections

Video Coaxial Cable Requirements for Pelco Spectra III

Cable Type *	Maximum Distance
RG59/U	750' (229m)
RG6/U	1000' (305m)
RG11/U	1500' (457m)

Minimum cable requirements

- 75 ohms impedance
- All-copper center conductor
- All-copper braided shield with 95% braid coverage

1. Connect the four primary wires as follows (*Figure 3-3*).
 - a. Encoder plug RX+ to Pelco Spectra TX+.
 - b. Encoder plug RX- to Pelco Spectra TX-.
 - c. Encoder plug TX+ to Pelco Spectra RX+.
 - d. Encoder plug TX- to Pelco Spectra RX-.

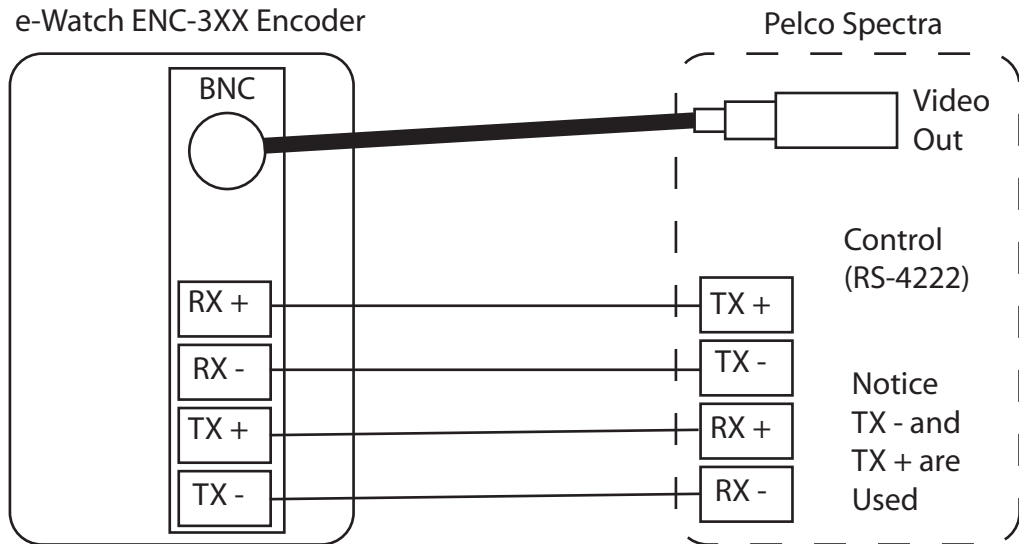

Figure 3-3 ENC to Spectra Wiring

2. Connect the coax cable to the top BNC connector on the Encoder.
3. Connect the other end of the coax cable to the video out BNC connector on the Pelco Spectra.

User Interface

To set up the user interface of the Pelco Spectra, you will need to use the SiteWatch™ application. This part of the installation assumes you have installed and configured the SiteWatch application. Proceed to the camera definition window of the SiteWatch application (*Figure 3-4*). Create a new or edit an existing camera definition. At the “External Device” drop down list, select Pelco Spectra III (*Figure 3-5*). Complete the camera definition as outlined in the SiteWatch Situational Awareness Administration Guide.

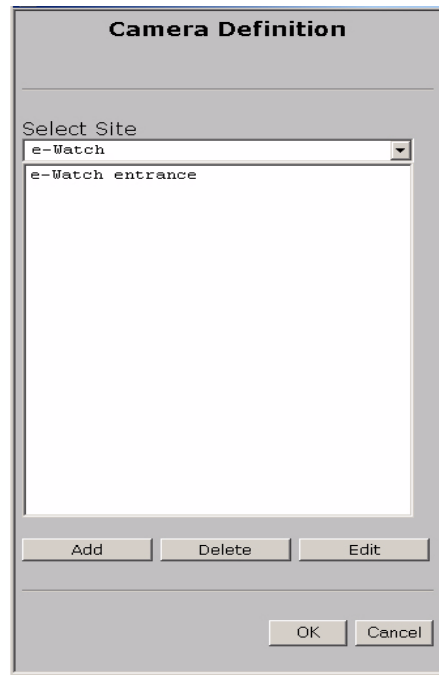

Figure 3-4 Camera Definition Scree

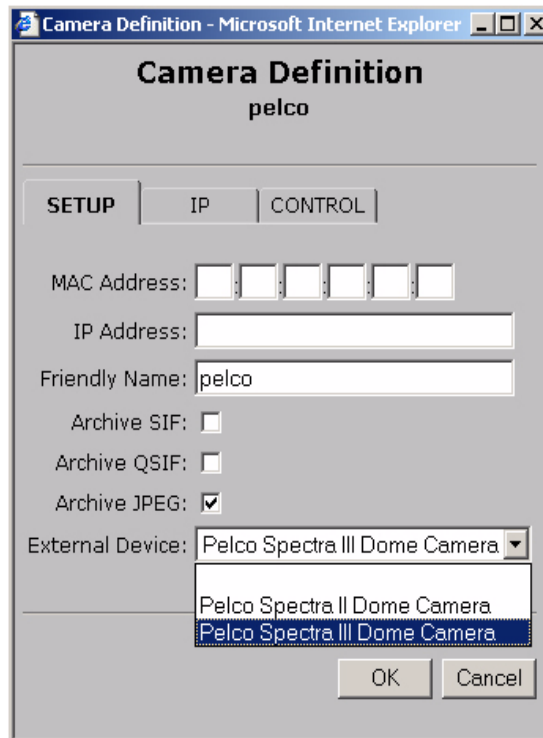

Figure 3-5 Camera Setup Screen

Testing

If the Pelco Spectra does not respond to camera control commands, follow this procedure to test the Encoder adapter card and the wiring connections. You will need to install the e-Watch Diagnostic Package program, version 3.0.1.2 or higher.

Disconnect the four primary wires from the back of the Encoder. Make the loopback connections RX+ to TX+ and RX- to TX- as shown in *Figure 3-6*. Run the e-Watch Diagnostic Package Viewer program. Connect to the SiteWatch server, select the Pelco Spectra camera in the dropdown Camera list, then click the Connect button. A tab labeled “Test Dome” should appear next to the Camera and Agents tabs. Click the Test Dome tab, then click the Test button. If the program reports “FAILED”, then the adapter card in the Encoder is probably faulty and should be returned to e-Watch for repair or replacement. If the program reports “PASSED”, then reconnect the four primary wires to the back of the Encoder and proceed to the next step.

Please refer to the Pelco Spectra III installation manual C2442M (2/02) for specific instructions relating to the following steps. Open the Pelco Spectra wiring interface, then make the loopback connections RX+ to TX+ and RX- to TX- as shown in *Figure 3-6*. Again run the e-Watch Diagnostic Package Viewer program, connect to the Pelco Spectra camera, click the Test Dome tab, then click the Test button. If the program reports “FAILED”, then there is probably a fault in one of the four primary wires connecting the Encoder to the Pelco Spectra. Make sure that the wires are connected as shown in *Figure 3-3*, and that they are not open or shorted. If the program reports “PASSED”, then there is a problem with the Pelco Spectra. Make sure the the SW switches are set as shown in *Figure 3-1*. Use the switch numbers embossed on the switch to determine the location of SW1-1, not any paper label that might be present. If the switches are set correctly, then the Pelco Spectra is probably faulty and should be returned for repair or replacement.

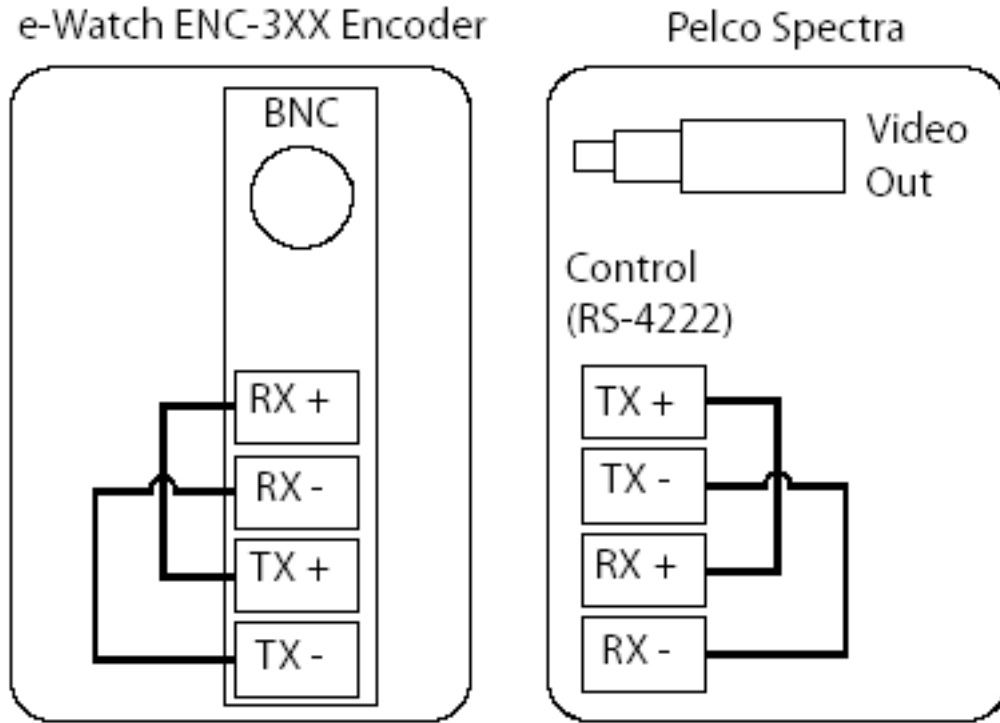

Figure 3-6 Loopback Connections

Customer Supplied Equipment

The following equipment and tools are required.

1. **Equipment**
 - a. **Pelco Spectra II or III pendant or dome camera.**
 - b. **Cabling to connect the Encoder to the IP network.**
 - c. **Power to the Encoder, either using an IEEE 802.3af PoE device or 12 VDC adapter.**
 - d. **Power to the dome is 24VAC, 40vA for indoor, 100vA for outdoor models with heater.**
 - e. **Cabling to connect the Pelco unit to the Encoder:**
 - a. **Coaxial cable**
 - b. **CAT5 cable for controls**
2. **Tools**
 - a. **#1 Phillips screwdriver.**
 - b. **Small common screwdriver.**