



e-Watch Camera Installation Guide

Model No.

CAM-32X, 33X, 35X

e-Watch®

PREFACE

The e-Watch CAM-32X, CAM-33X, and CAM-35X cameras and encoders are Ethernet ready devices designed for use with e-Watch software. In order to get the benefits of these cameras it is necessary to connect them to an e-Watch® Situational Awareness System.

PRECAUTIONS

1. Do not attempt to disassemble this unit.

To prevent electrical shock, do not remove screws or covers. Service should be conducted by a qualified service personal.

2. Handle the camera with care

Do not drop, strike or shake camera. Damage may occur by improper handling or storage.

3. Do not expose the camera to rain or moisture.

Camera mounting in outside or wet areas requires an environmental housing. Disconnect power in the event the camera becomes wet, and request service by a qualified service personal.

4. Do not use strong or abrasive cleaners.

Use a clean dry fabric cloth to clean camera housing. Do not use paper-based tissue or towel. Clean lenses with lens tissue or cotton and mild lens cleaning solution.

5. Never face the camera toward the sun.

Damage can occur if the camera is directed at a bright light source.

6. Do not operate the camera beyond the specified environmental and power ratings.

Operation of cameras in environments not within the specifications requires installation in special environmental housings.

7. Caution removing fiber optic plugs

Take caution when removing the fiber optic plugs on both the camera and the fiber optic cable.

Power Requirements

The following are the power requirements for the devices.

1. CAM-32X, 33X, 35X = 24 VAC/ 12 VDC Regulated $\pm 10\%$
2. External Enclosure = Independent power requirements may be applicable for external enclosures with powered options.

Fiber Connection

The following are the fiber connection requirements for the devices

1. CAM-32X = Multimode Duplex SC
2. CAM-33X = Singlemode Duplex SC
3. CAM-35X = Singlemode MTRJ

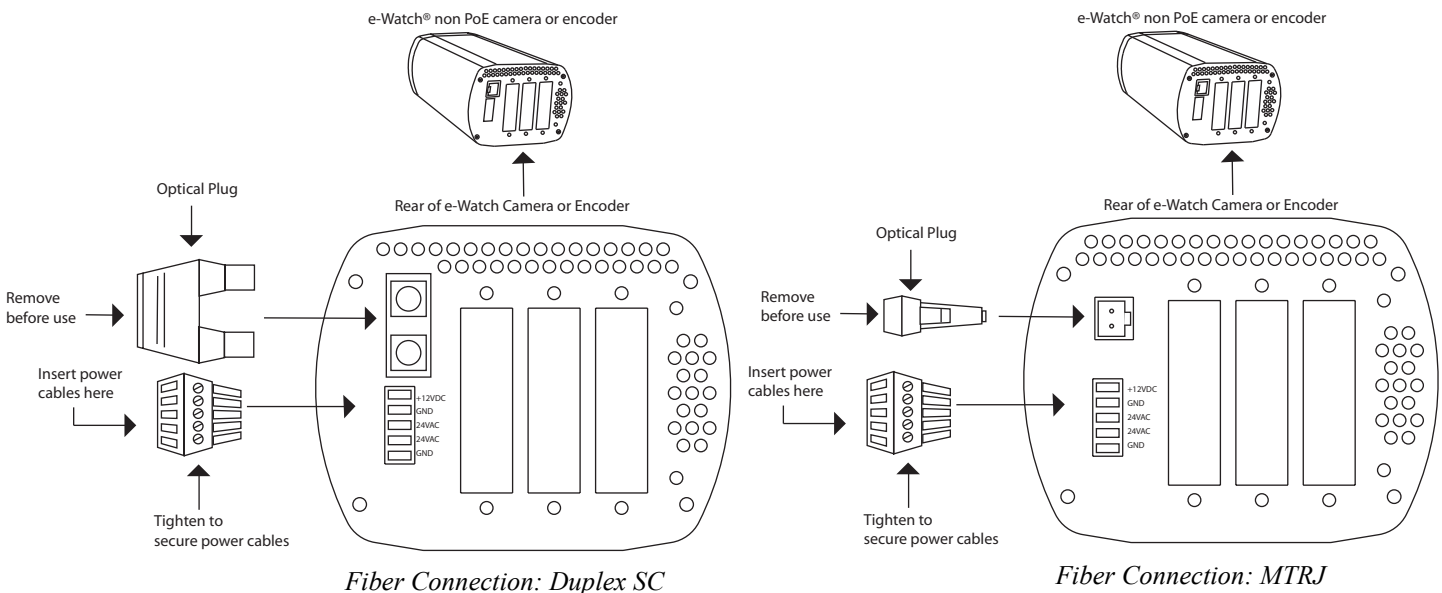

MOUNTING

CAM or Encoder

A 1/4 -20 threaded mounting hole is provided on the bottom and the top of the camera for attachment. Insert a 1/4 -20 fastener through mounting bracket, thread into the camera body and secure. Mounting screw should not intrude into the camera body more than 3/8 inch on the bottom hole or 1/2 inch on the top hole. Damage can result if intrusion into the housing is over recommended length or the fastener is over tightened.

External Enclosure

Depending on the mounting location, special mounting brackets may be required for external enclosures.

Connections

Ethernet Connection

Ethernet connection is provided via a fiber optic connector on the rear of the camera. Cameras are DHCP devices and will automatically obtain their addresses from the server running DHCP services.

After the server assigns the device an IP address it is recommended the addresses be reserved.

Fiber Connection

Singlemode versions use either a Singlemode Duplex SC connector or a MTRJ connector.

Multimode versions use a Duplex SC connector.

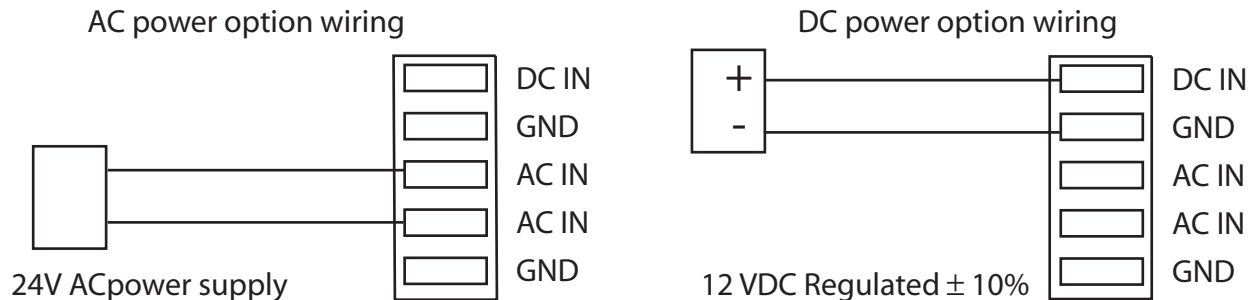

This unit complies and has been tested to or is listed through the following organizations:



This device complies with part 15 of the FCC Rules. Operation is subject to the following two conditions: (1) This device may not cause harmful interference, and (2) this device must accept any interference received, including interference that may cause undesired operation. Changes or modifications to this device not expressly approved by the party responsible for compliance could void the user's authority to operate the equipment.

e-Watch Corporation
7800 IH-10 West, Suite 720
San Antonio, TX 78230
USA

tel: (210) 349-2000
fax: (210) 341-1020

For more information:

email:
sales@e-watch.com

website:
www.e-watch.com

Copyright© 2006 e-Watch Corporation. All rights reserved. e-Watch is a registered trademark of e-Watch Corporation. ViewWatch, DecisionWatch, EventWatch, SiteWatch, MotionWatch, GateWatch, AirWatch, PocketWatch, PeopleWatch, BankWatch, ClassWatch, ObjectWatch, WatchLink, Activity Gated Storage, and Gigapixel are trademarks of e-Watch Corporation. Any other trademarks mentioned in this document are the property of their respective owners. The use of the word partner does not imply a partnership relationship between e-Watch Corporation and any other company.